

SP 3300 LI
SP 3500 LI
SP 3800 LI

We care.

Customised Pumps - No Additional Costs!

Product Features

- Oil free
- Maintenance free
- Reduced vibrations
- Flat casing (56 mm)
- Advanced design
- Cost effective

Application Examples

Particularly suitable for stationary devices such as:

- Battery Chargers
- Cooling
- Pneumatics
- Industrial Applications

Customisation

- We offer your customised precision pump without additional costs - even for small batches
- Outstanding quality - Made in Germany
- Excellent technical consultation and service by experts
- More than 40 years experience in pump applications
- Fast delivery - order your sample now!



Schwarzer
Precision

Am Lichtbogen 7 • 45141 Essen • Germany
Phone: +49 201 31697-0 • Fax: +49 201 31697-29
e-mail: info@schwarzer.com • <https://www.schwarzer.com>



SP 3300 / 3500 / 3800 LI

The pumps listed below represent a typical selection of our wide range of eccentric pumps and are intended for initial tests. **Customised versions** for your individual application would be made without additional costs - please contact us! All flow values given under norm conditions (according to DIN 1343). Optional materials can cause deviating performance values.

Designation	SP 3300 LI-D	SP 3300 LI-DV	SP 3500 LI-D	SP 3500 LI-DV	SP 3800 LI-D	SP 3800 LI-DV
Operating Voltage	230 V (50 Hz)		230 V (50 Hz)		230 V (50 Hz)	
Operating time	continuous operation		continuous operation		intermitted operation only	
Art.-No.	7s77025	7s77000	7s77026	7s77001	7s77027	7s77002
Pneumatic Performance						
Free Flow [l/h]	880	880	900	940	1250	1250
flow at: Pressure Side						
100 mbar [l/h]	300	300	500	500	800	800
max. Pressure [mbar]	150	150	210	210	270	270
flow at: Vacuum Side						
-100 mbar [l/h]	-	300	-	360	-	730
max. Vacuum [mbar]	-	-150	-	-160	-	-240
Motor / Power Consumption						
Motor Type			Electromagnetic			
Power Consumption [W]	12		15		24	
Construction						
Pump Head	standard		PA reinforced			
	optional		-			
Diaphragm / Seal	standard		EPDM / NBR			
	optional		-			
Valves	standard		EPDM			
	optional		-			
Weight [g]	950		950		950	

Performance Curves

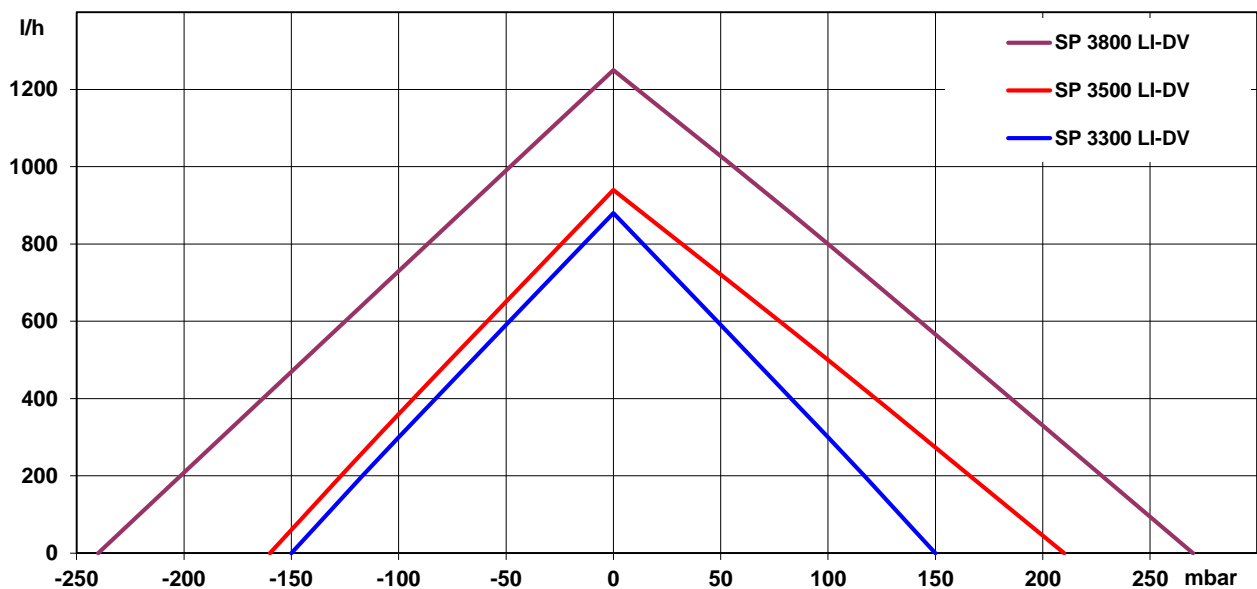

Am Lichtbogen 7 • 45141 Essen • Germany
 Phone: +49 201 31697-0 • Fax: +49 201 31697-29
 e-mail: info@schwarzer.com • <https://www.schwarzer.com>

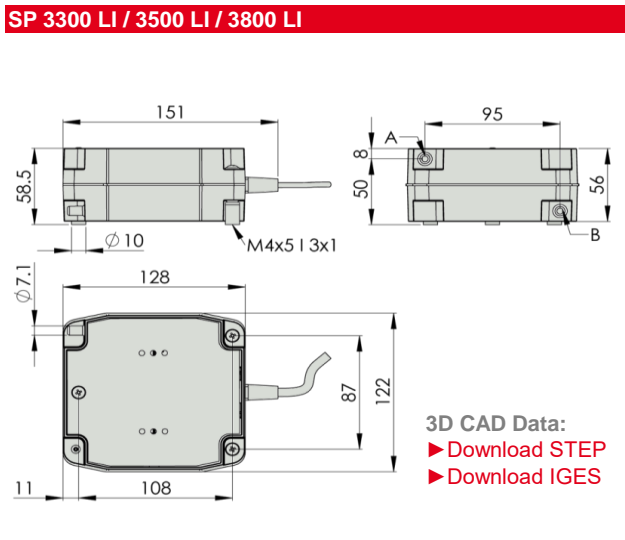

Designation	Pump equipped with Nozzle	Function of Nozzle	
		A	B
LI-D = Pressure only	A only	Outlet	-
LI-V = Vacuum only	A only	Inlet	-
LI-DV = Press. + Vac.	A + B	Outlet	Inlet

Accessories

Schwarzer Precision offers a comprehensive portfolio of pump accessories such as:

- mountings
- silencers + filters
- electronics
- check valves + pressure switches

For further information please consider the accessories data sheet or contact us for technical consultation.

▶ [Download PDF "Accessories"](#)

You can also download the PDF "Accessories" on our website:

▶ www.schwarzer.com/accessories